

CPE-4000 Part List

Lastly Modified at 26th-Feb-2010(V3.1)

Written by CS team

※ Unit price is based on BOM MC the date Feb. 28, 2008 written by purchasing & Material team



A-1



A-2



A-3

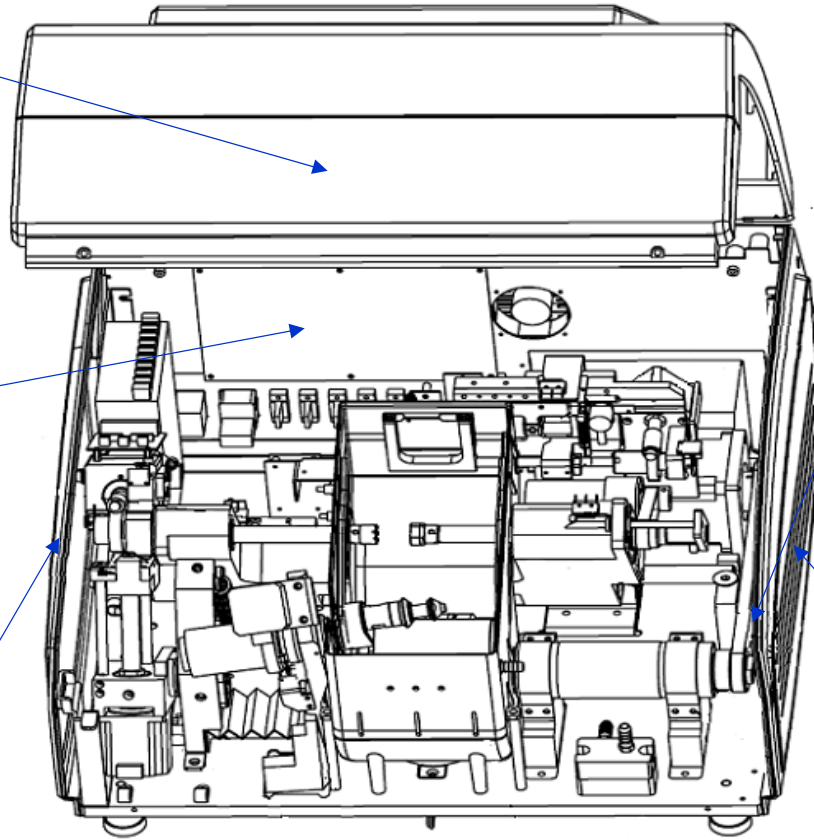

A-5



A-4

Ref. No.	Part Name	BOM Code	Remarks (for reference)	Q'ty
A-1	COVER FRONT	2000A00G006-A		1
A-2	COVER BACK	2000A00G007-A		1
A-3	COVER SIDE LEFT	2000MPOG001-A		1
A-4	COVER SIDE RIGHT	2000MPOG002-A		1
A-5	BELT (POLYMAX 5M-615-2R)	3006A000004-A	Wheel Belt	1

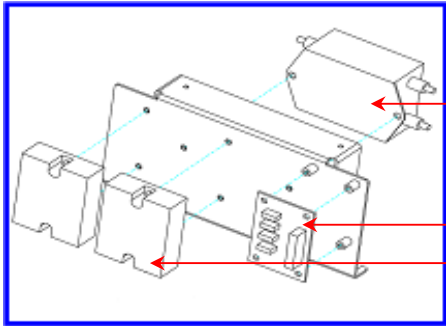

B-1-4

B-1-3

B-1-1

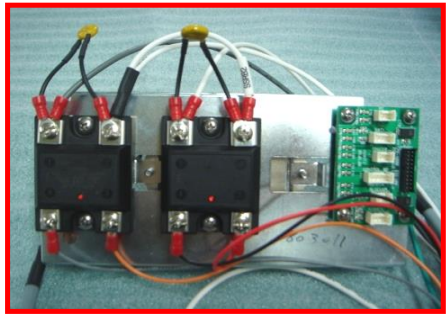

<B-1. ELECTRIC SSR ASS'Y>

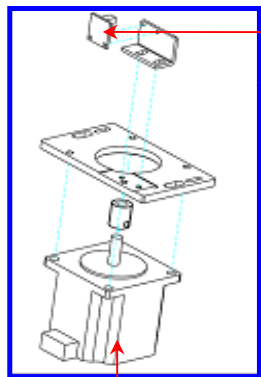

B-2-2

B-2-1



<B-2. X MOVING ASS'Y (CPE)>

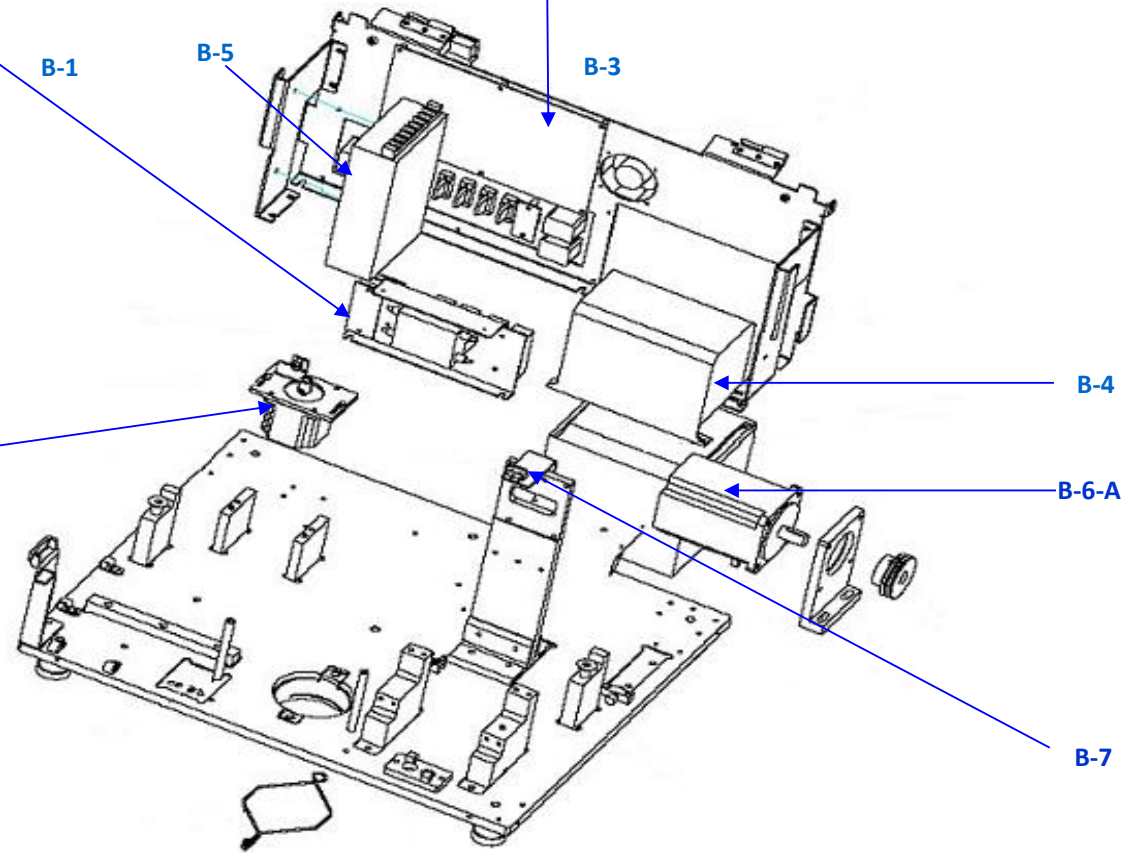

B-1

B-5

B-3

B-4

B-6-A

B-7

Ref. No.	Part Name	BOM Code	Remarks (for reference)	Q'ty
B-1	ELECTRIC SSR ASS'Y	G0MASSY130-AA	Assembly	1
B-1-1	SSR (KSD215AC9)	7622S002158-A		2
B-1-2	HARNESS(SSR VARISTOR)	G0EHAR0016-AA		2
B-1-3	PCB ASSY(EGI-100)	G0EPCB2002-AA	GUI Communication B/D	1
B-1-4	NOISE FILTER	6810F000110-A		1
B-2	X MOVING ASS'Y (CPE)	G0MASSY150-AA	Assembly	1
B-2-1	HARNESS(X Axis MOTOR(X-Axis))	G1EHAR6006-AB	With step motor	1
B-2-2	HARNESS(X AXIS PI(M.J6))	G0EHAR3005-AB		1
B-3	PCB ASSY (ECM-103)	G0EPCB7001-AD	Motor Board	1
B-4-1	SERVO MOTOR DRIVER(CPE 220V)	6430TMT2460-A	The 220V Wheel Inverter	1
B-4-2	SERVO MOTOR DRIVER(CPE 110V)	6450TM38110-A	The 110V Wheel Inverter	1
B-5	SMPS (IAPT-120A)	7560PG00220-A		1
B-6-A	MOTOR(WHEEL MOTOR), 220V	6430TMT0004-B	It's belt type motor for 220V	1
B-6-B	SERVO MOTOR-110V	6450T004A01-B	It's belt type motor for 110V	1
B-7	HARNESS(DOOR OPEN CHECK LIMIT SWITCH)	G0EHAR4001-AB		1

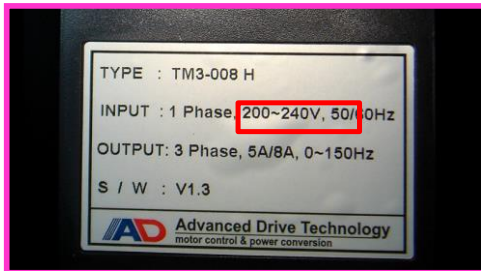
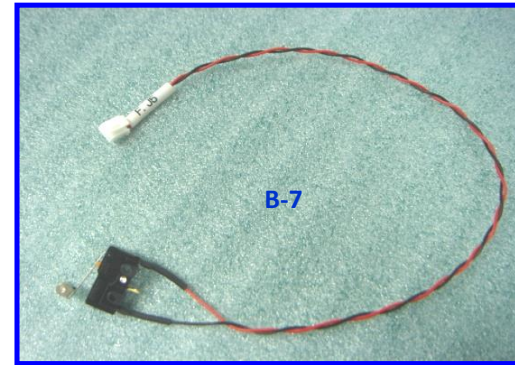
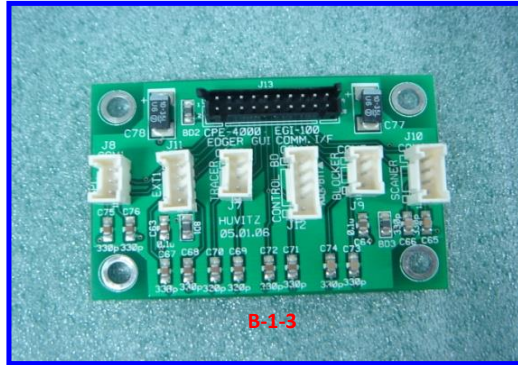

B-4 -1

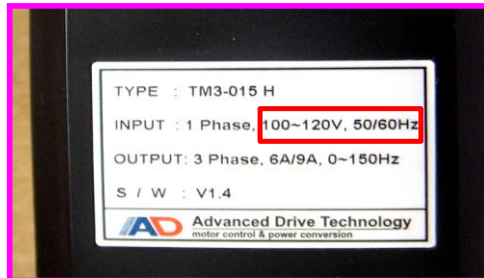

B-4-2



B-6 -A



B-6 -B

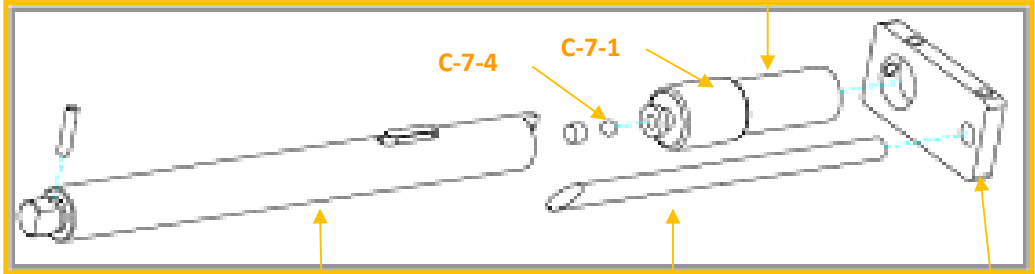
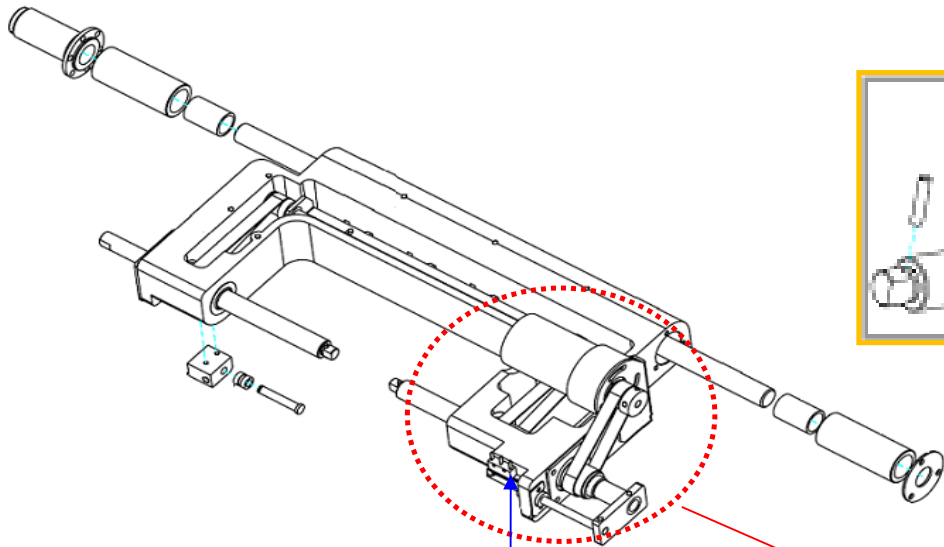

C-1

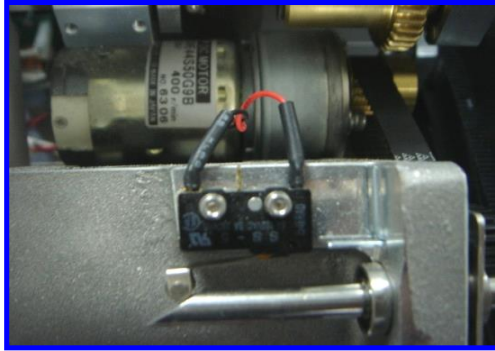

<HARNESS(CLAMP LIMIT SWITCH(M.J12))>

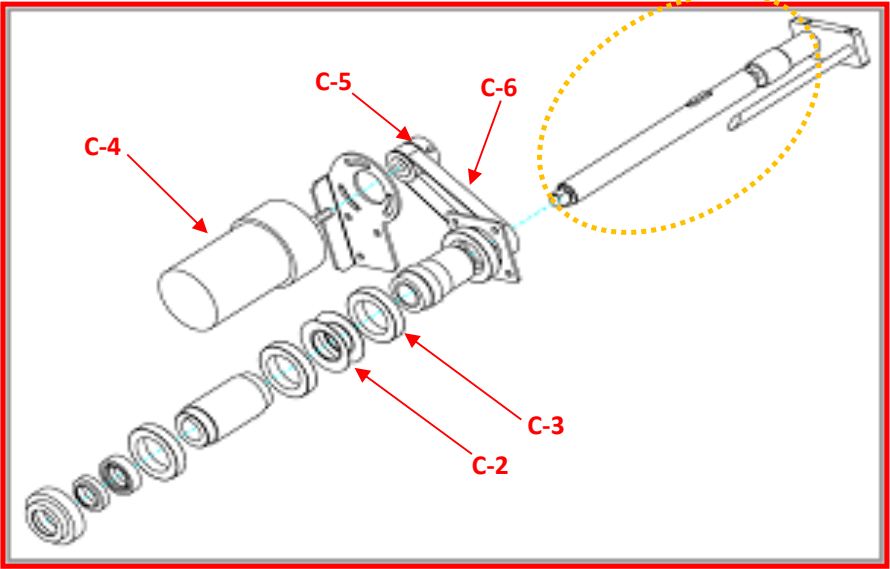

Ref. No.	Part Name	BOM Code	Remarks (for reference)	Q'ty
C-1	HARNESS(CLAMP LIMIT SWITCH(M.J12))	GOEHAR4004-AC	CLAMP LIMIT SWITCH(M.J12)	1
C-2	DISK SPRING (36.6*20.4-0.5t)	1557A000366-A		2
C-3	BEARING (6805ZZ)	3002A000011-A		4
C-4	HARNESS(CLAMP DC MOTOR)	GOEHAR6008-AB	With DC Motor	1
C-5	CHUCK MOTOR PULLEY 3M 21	1220A00G001-A		1
C-6	BELT (S3M-213-10W)	3006A000001-A		1
C-7	CHUCK MOVING PULLEY ASS'Y	CSMASSY001	Assembly	1
C-7-1	CHUCK MOVING PULLEY 3M 26	1230A00G002-D		1
C-7-2	BEARING (6805ZZ)	3002A000011-A		1
C-7-3	CHUCK MOVING SCREW	1210A00G008-C		1
C-7-4	BEARING STILL BALL	3002A00S002-A		1
C-8	CHUCK SHAFT	1210A00G007-D		1
C-9	CHUCK SCREW PLATE	1200A00G009-A		1
C-10	CHUCK GUIDE SHAFT	1210A00G009-A		1



<C-7. CHUCK MOVING PULLEY ASS'Y>



<DRAWING of CHUCK MOVING PULLEY ASS'Y>

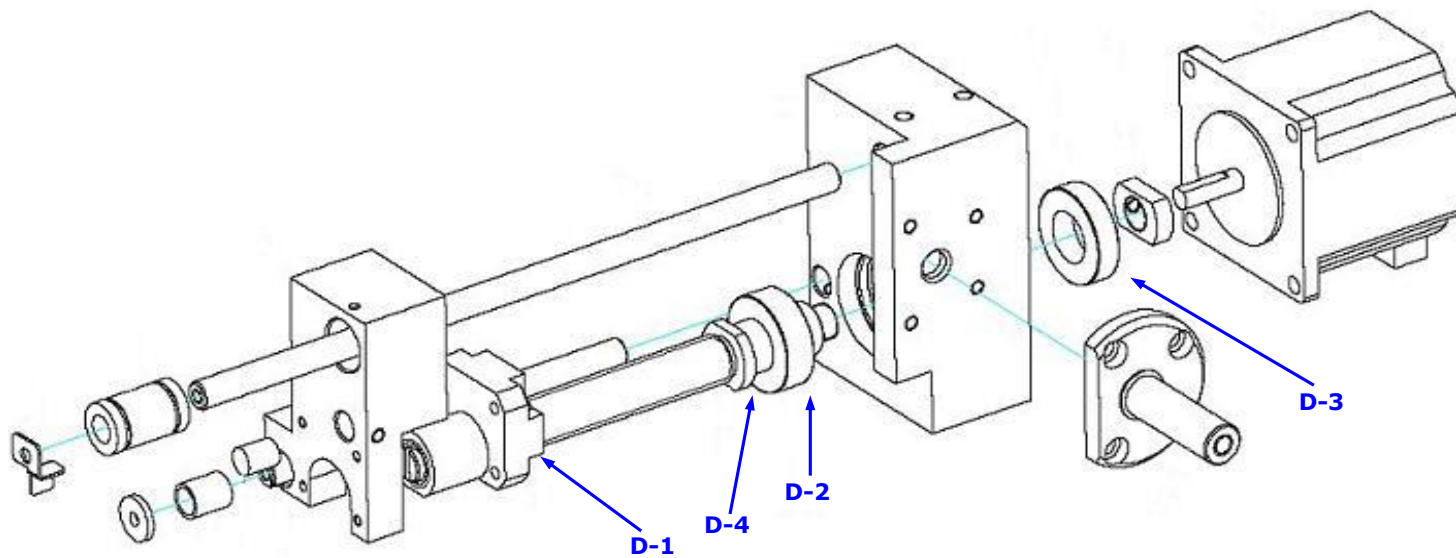

<D. LIFT Z MOTOR ASS'Y>



Ref. No.	Part Name	BOM Code	Remarks (for reference)	Q'ty
D	LIFT Z MOTOR ASS'Y	G0MASSY231-AA	Assembly	1
D-1	LIFT TM NUT(M)	2020A00G006-A		1
D-2	BEARING (51102)	3002A000014-A		1
D-3	BEARING (6902ZZ)	3002A000013-A		1
D-4	LIFT TM SCREW	1210A00G015-B		1

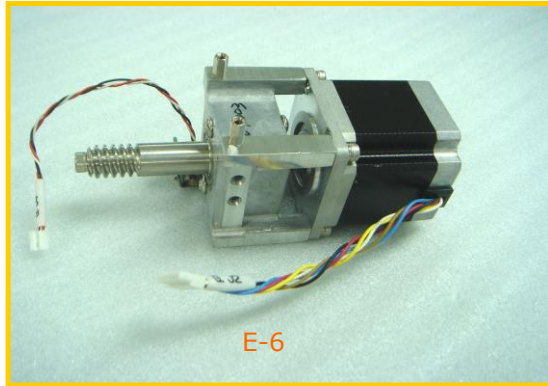
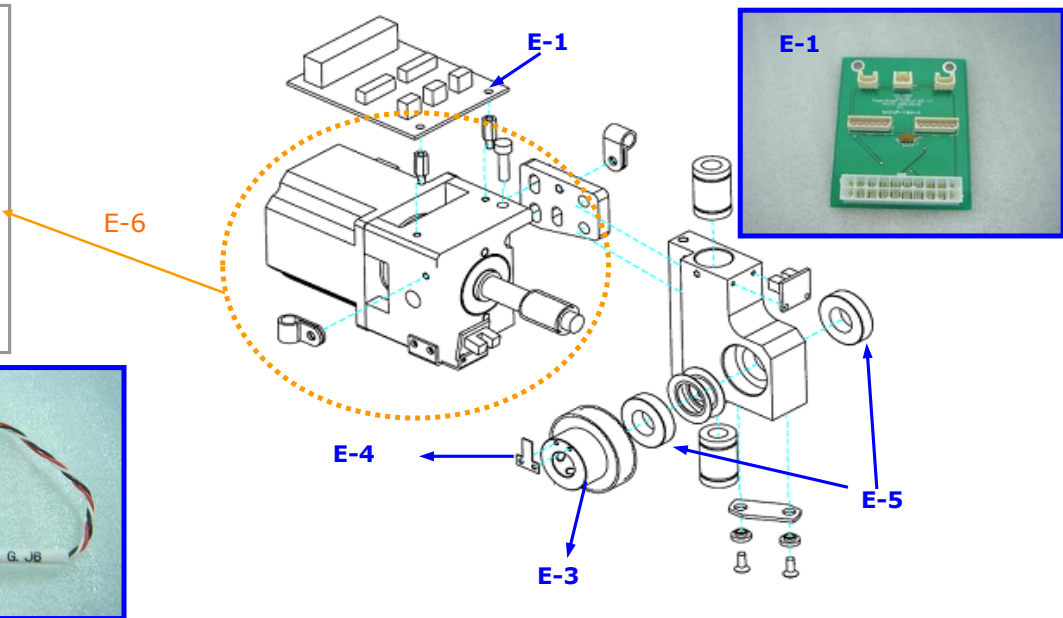
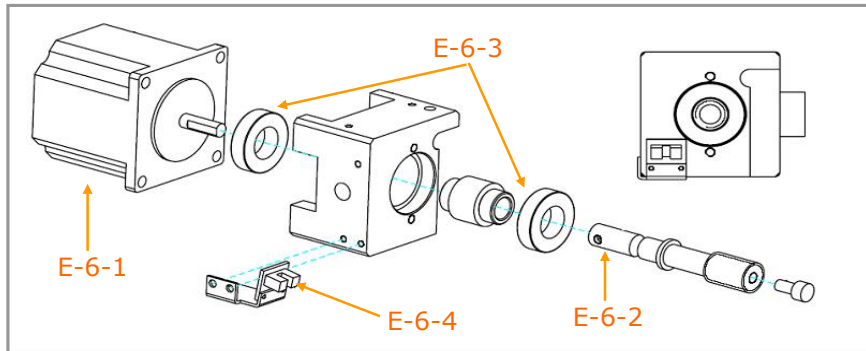

<E-6. ROTATION WORM ASS'Y>

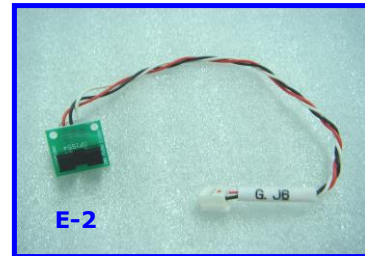

<E-7. ROTATION MOTOR



Ref. No.	Part Name	BOM Code	Remarks (for reference)	Q'ty
E-1	PCB ASSY(ECG-101)	G0EPCB8002-AA		1
E-2	HARNESS(Y AXIS PI(G.J6))	G1EHAR3003-AD		1
E-3	ROTATION WORM WHEEL	1220A00G005-B		1
E-4	WORM WHEEL PI DOG	1310A00G014-C		1
E-5	BEARING (6901ZZ)	3002A000012-A		2
E-6	ROTATION WORM ASS'Y	G0MASSY239-AA	Assembly	1
E-6-1	HARNESS(ROTATION MOTOR(G.J2))	G0EHAR6002-AC	With step motor	1
E-6-2	ROTATION WORM	1210A00G022-C		1
E-6-3	BEARING (6902ZZ)	3002A000013-A		2
E-6-4	HARNESS(ROTATION PI E (G.J4))	G0EHAR3004-AB		1
E-7	ROTATION MOTOR PLATE ASS'Y	G0MASSY232-AA	Assembly	1

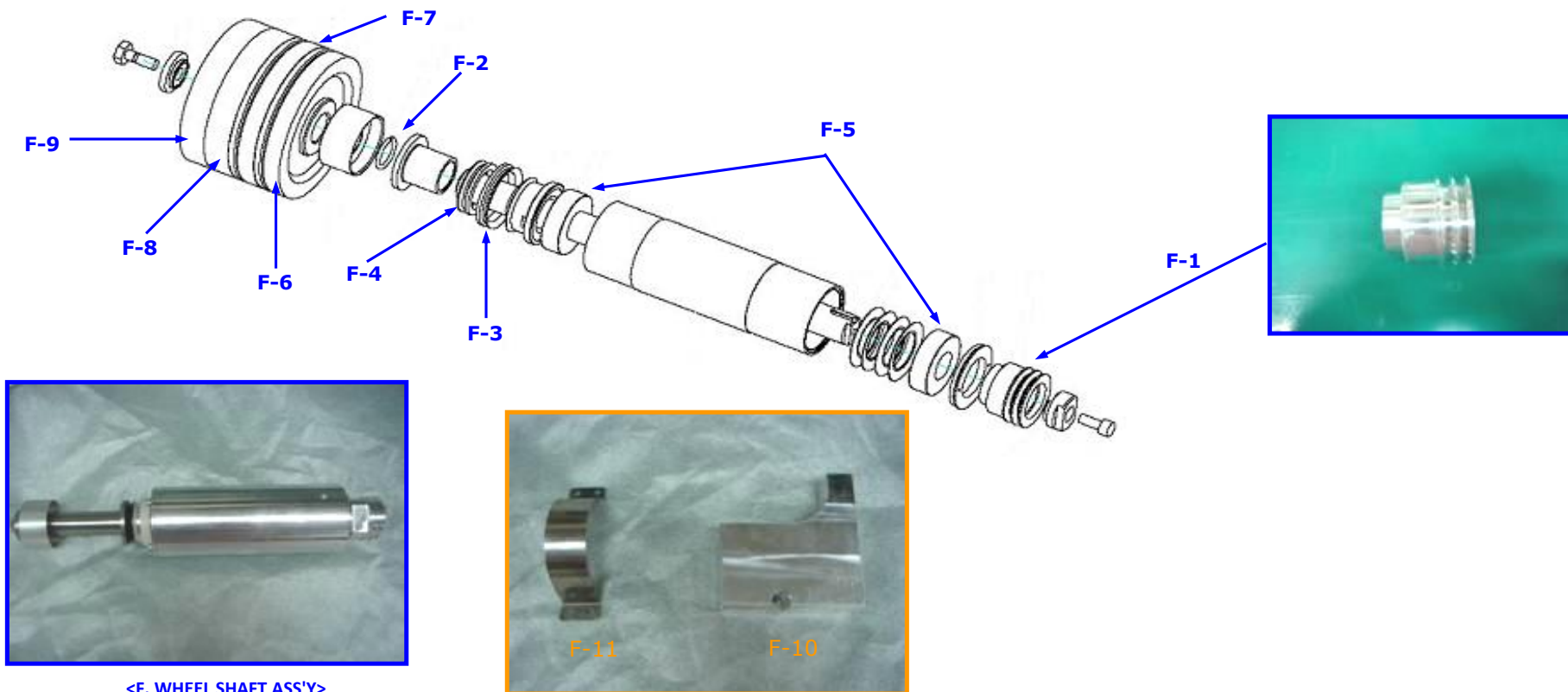

<F. WHEEL SHAFT ASS'Y>

Ref. No.	Part Name	BOM Code	Remarks (for reference)	Q'ty
F	WHEEL SHAFT ASS'Y	GOMASSY300-AA	Assembly(Without 4 wheels)	1
F-1	SHAFT SMALL PULLEY	1210A00G029-C		1
F-2	O RING	3004A000001-A	Inside Diameter 17.8-Thickness 2.4	1
F-3	V RING (35)	3004A000005-A		1
F-4	V RING (28)	3004A000007-A		1
F-5	BALL BEARING (6004ZZ)	3002A000044-A		2
F-6	WHEEL POLISHING	1250MZ0G001-C		1
F-7	WHEEL FINISHING	1250MZ0G002-C		1
F-8	WHEEL ROUGHING GLASS	1250MZ0G003-B		1
F-9	WHEEL ROUGHING PLASTIC	1250MZ0G004-B		1
F-10	BASE PLATE SUPPORT4	1200A00G006-D	* When you replace "Wheel Shaft Ass'y", you replace these parts together.	2
F-11	SHAFT ASSY FIXER1	1310A00G003-B		2

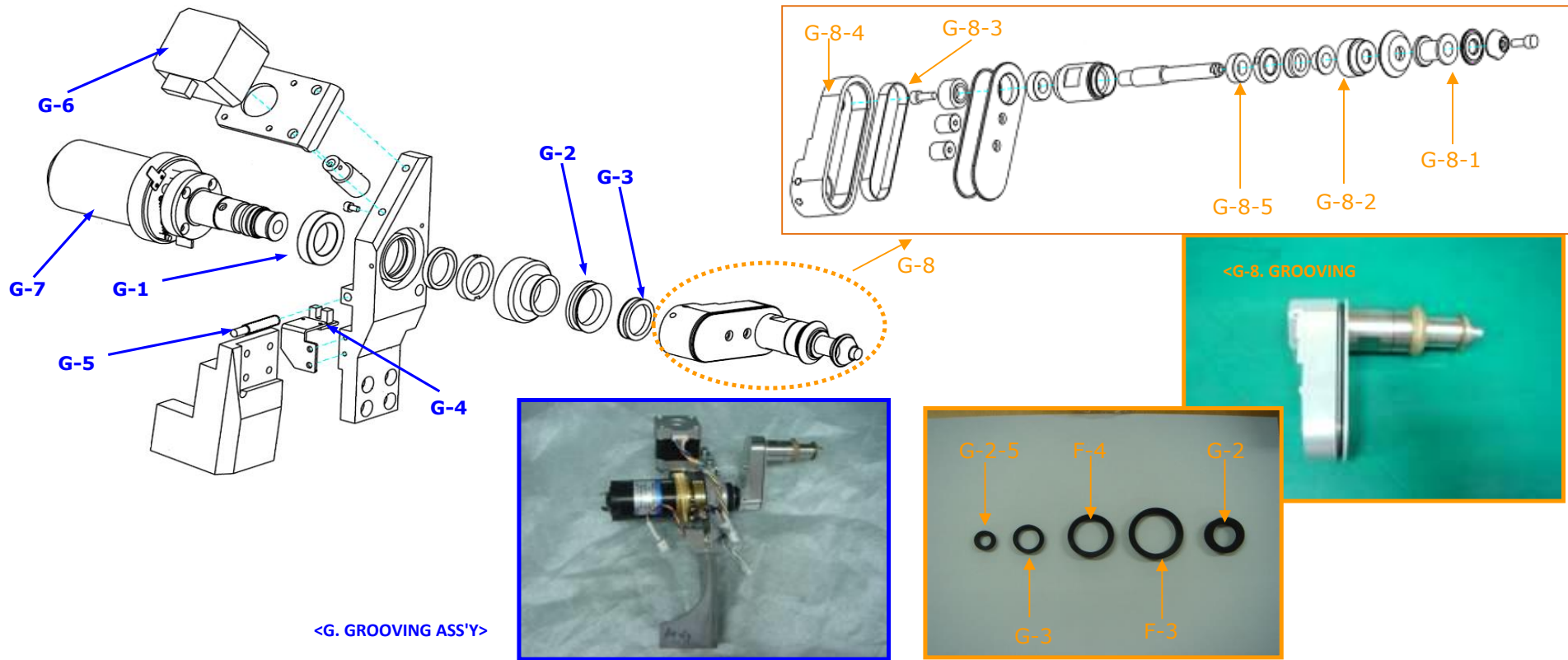

<G. GROOVING ASS'Y>

Ref. No.	Part Name	BOM Code	Remarks (for reference)	Q'ty
G	GROOVING ASS'Y	GOMASSY500-AA	Assembly	1
G-1	BEARING (6804ZZ)	3002A000016-A		1
G-2	GROOVING SPONGE	3016A000005-A	"V RING(22)" is changed	1
G-3	V RING (18)	3004A000008-A		1
G-4	HARNESS(SBG1 PI (EXP. CABLE))	G0EHAR3007-AC		1
G-5	HARNESS(SBG2 (EXP. CABLE))	G0EHAR4003-AC	Ball Planger Switch	1
G-6	MOTOR(STEP)	6430TMT4S42-A		1
G-7	GROOVING MOTOR ASS'Y	G0MASSY510-AA	Assembly. Cannot replace only DC Motor.	1
G-8	GROOVING SHAFT ASS'Y	G0MASSY520-AA	Assembly	1
G-8-1	WHEEL GROOVING	1250MZ0G005-B		1
G-8-2	WHEEL BEVELING	1250MZ0G006-C		1
G-8-3	BEARING (688ZZ)	3002A000018-A		1
G-8-4	BELT (MXL75-6W)	3006A000003-A	Grooving Belt	1
G-8-5	V RING (10)	3004A000009-A		1

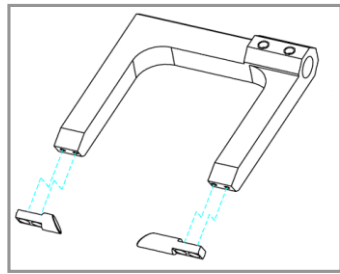

<H-2 FEELER TOUCH ARM ASS'Y>

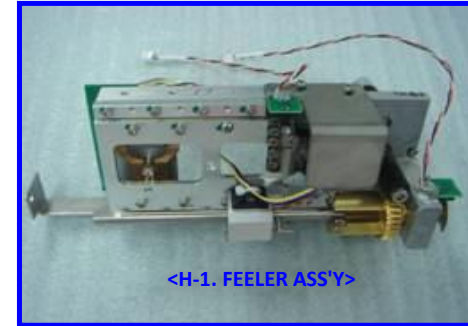
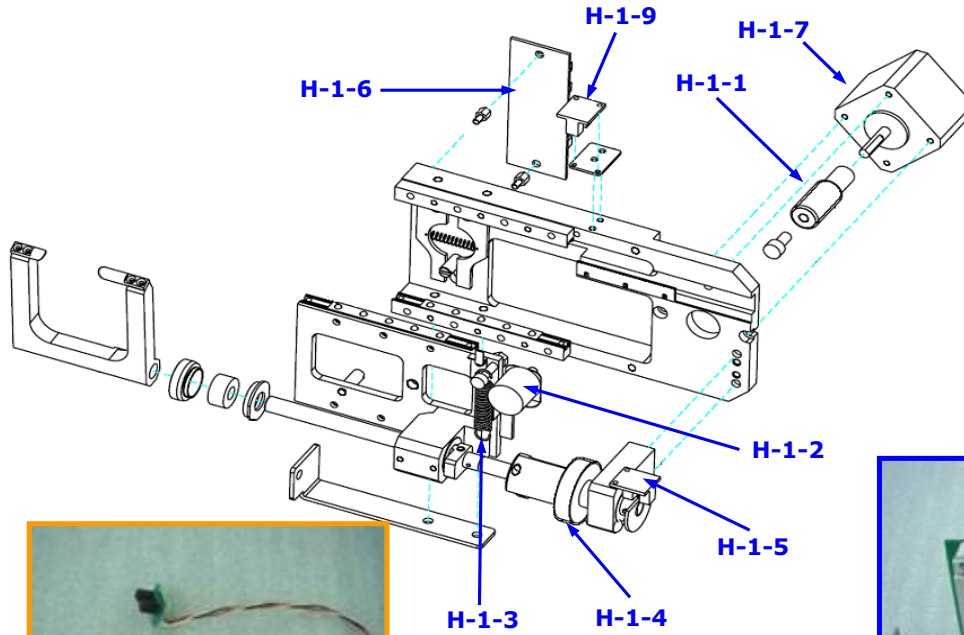

Ref. No.	Part Name	BOM Code	Remarks (for reference)	Q'ty
H-1	FEELER ASS'Y	G0MASSY600-AA	Assembly(Without "Feeler Touch Arm Ass'y")	1
H-1-1	FEELER ROTATE WORM	1210A00G043-D		1
H-1-2	HARNESS(FEELER ENCODER)	G0EHAR3008-AA	Rotary Encoder	1
H-1-3	SPRING (AUY 8-25)	3008A000018-A		1
H-1-4	FEELER WORM WHEEL	1220A00G014-A		1
H-1-5	HARNESS(ROTATION FEELER PI1(F.J4))	G0EHAR3001-AB		1
H-1-6	PCB ASSY(ECF-102)	G0EPCB8001-AA	FEELER INTERFACE B/D	1
H-1-7	MOTOR(STEP)	6430TMT4S42-A		1
H-1-8	HARNESS(FEELER MOTOR (F.J6))	G0EHAR6001-AC		1
H-1-9	HARNESS(SHIFT FEELER PI2(F.J3))	G0EHAR3002-AC		1
H-2	FEELER TOUCH ARM ASS'Y	G0MASSY640-AA	Assembly	1
H-2-1	NEW TOUCH ARM	1100A00G009-A		1
H-2-2	FEELER TIP SHORT	2050A00G002-A		1
H-2-3	FEELER TIP LONG	2050A00G003-A		1

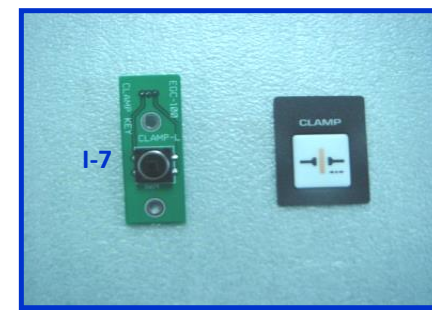
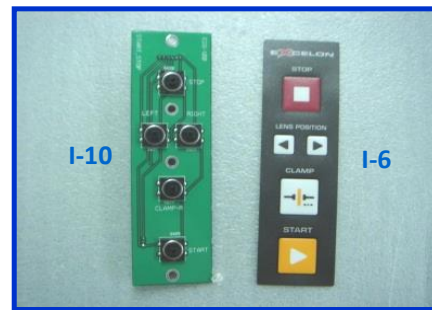
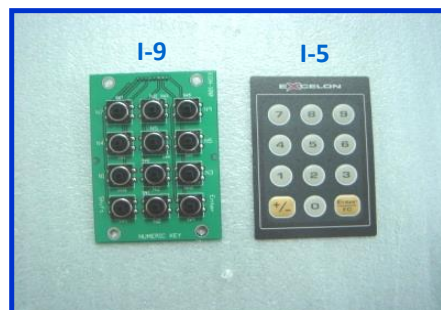
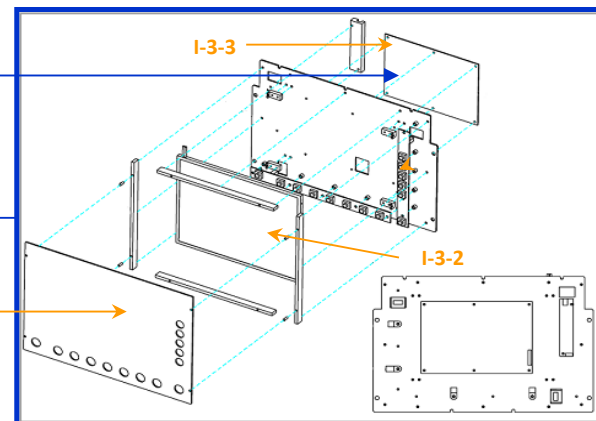
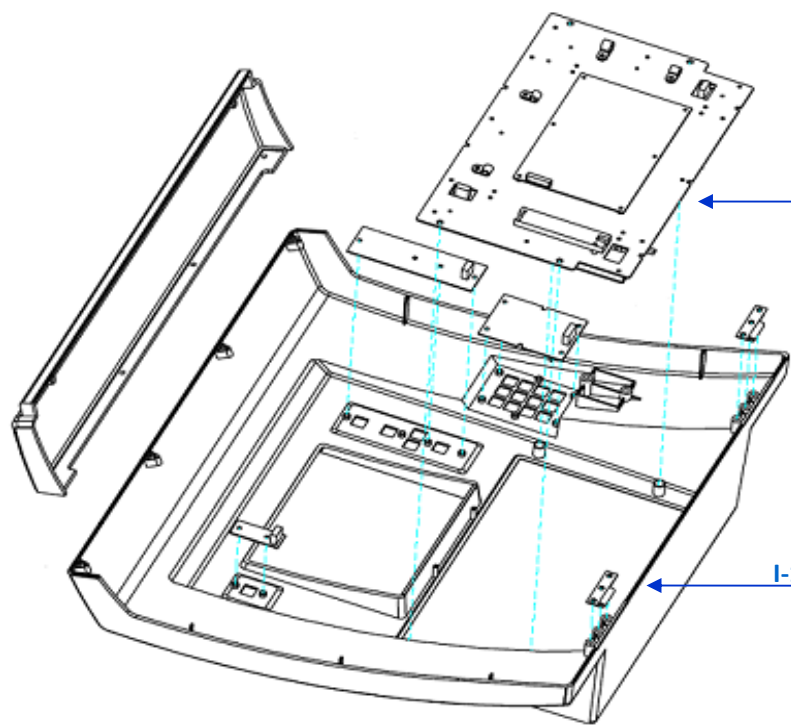

Ref. No.	Part Name	BOM Code	Remarks (for reference)	Q'ty
I-1	COVER MAIN	2000A00G005-C		1
I-2	COVER FRONT	2000A00G006-A		1
I-3	LCD ASS'Y	G0MASSY711-AA	Assembly(I-3-1~I-3-5). Without EGM-110.	1
I-3-1	LCD WINDOW	1230A00G010-A		1
I-3-2	LCD MONITOR	7202LGRLP10-A		1
I-3-3	LCD MONITOR INVERTER	7216D00LP10-A		1
I-3-4	PCB ASSY(KEY-100)	G0EPCB4001-AA	EGF-100, 20X250 8KEY	1
I-3-5	PCB ASSY(KEY-100)	G0EPCB4002-AA	EGR-100, 20X190 6KEY	1
I-4	CPE LCD PAD (KEY-14)	2200G000133-B		1
I-5	CPE TEN KEY PAD (KEY-12)	2200G000233-C		1
I-6	CPE R KEY PAD (KEY-5)	2200G000333-C		1
I-7	CPE L KEY PAD (KEY-1)	2200G000433-C		1
I-8	PCB ASSY (EGM-110)	G0EPCB1001-AD	GUI B/D. EGM-110.	1
I-9	PCB ASSY(KEY-100)	G0EPCB4003-AA	EGN-100, 90X60 12KEY	1
I-10	PCB ASSY(KEY-100)	G0EPCB4004-AA	EGS-100, 130X40 5KEY	1
I-11	PCB ASSY(KEY-100)	G0EPCB4005-AA	EGC-100, 20X50 1KEY	1
I-12	HARNESS(INVERTER CABLE)	G0EHAR1001-AA		1
I-13	HARNESS(20P-20P(LCD TO M.J13))	G0EHAR7002-AA		1
I-14	HARNESS(LCD CABLE 20P-20P)	G0EHAR7005-AA		1

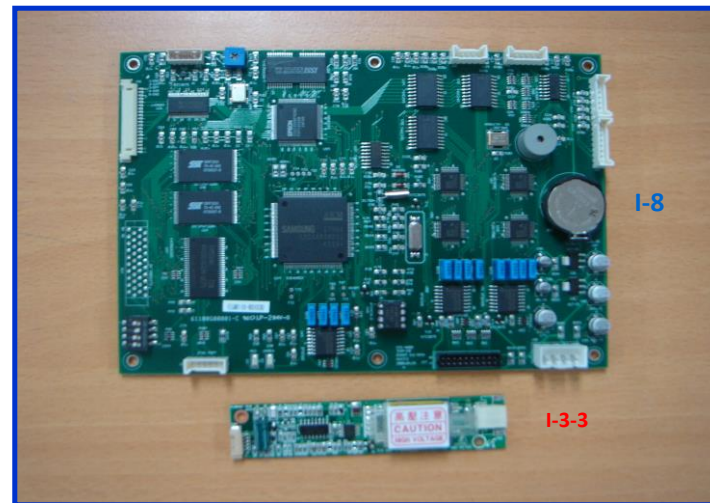
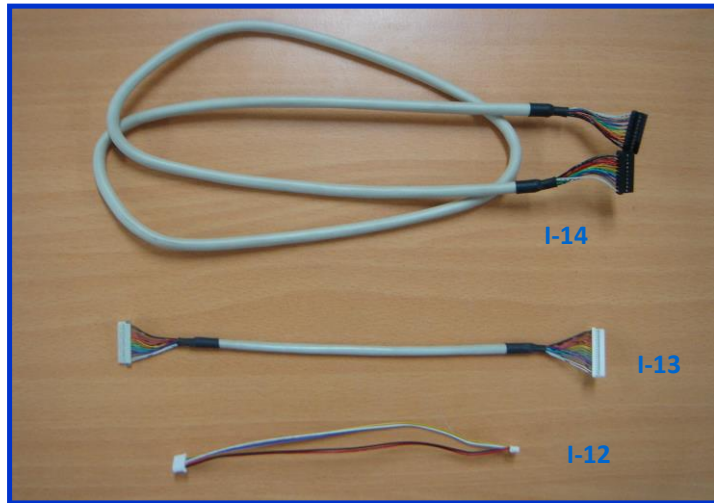

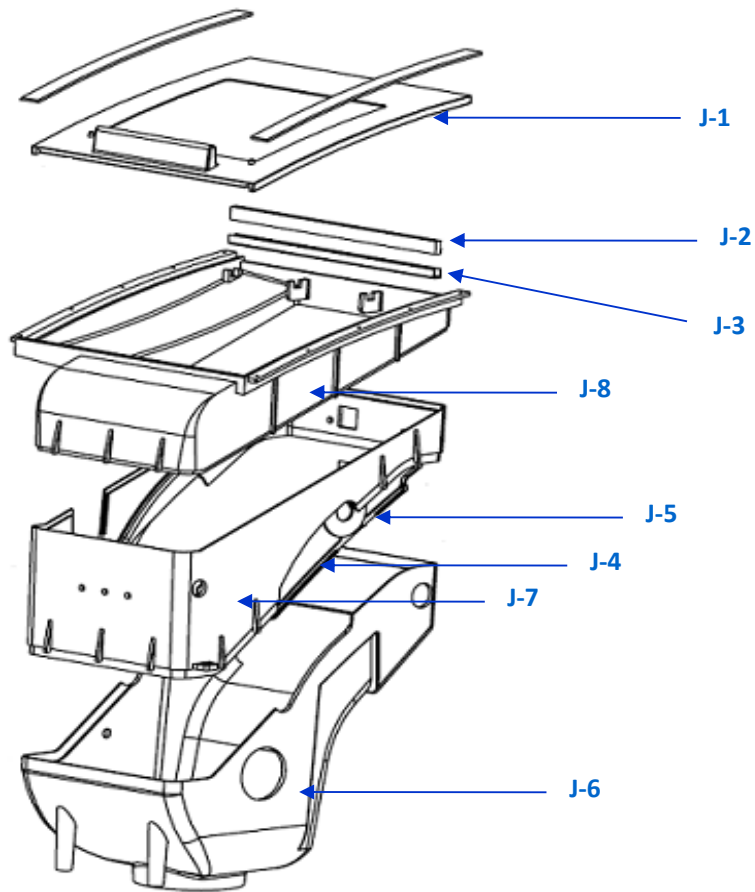

<J. EDGING ROOM ASS'Y>

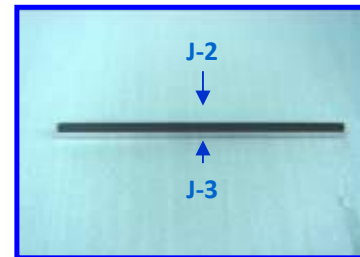

Ref. No.	Part Name	BOM Code	Remarks (for reference)	Q'ty
J	EDGING ROOM ASS'Y	GOMASSY410-AA	Assembly	1
J-1	EDGING ROOM WINDOW	2010A00G001-B		1
J-2	CHROLOPRENE SPONGE	3016A000002-A		1
J-3	EDGING WINDOW BRUSH BRACKET	1310A00G017-A		1
J-4	EDGING ROOM SLIDER	2020A00G001-C		2
J-5	EDGING ROOM SHAFT BUSH	1230A00G006-A		2
J-6	EDGING ROOM 1	2000A00G001-A		1
J-7	EDGING ROOM 2	2000A00G002-B		1
J-8	EDGING ROOM 3	2000A00G003-B		1

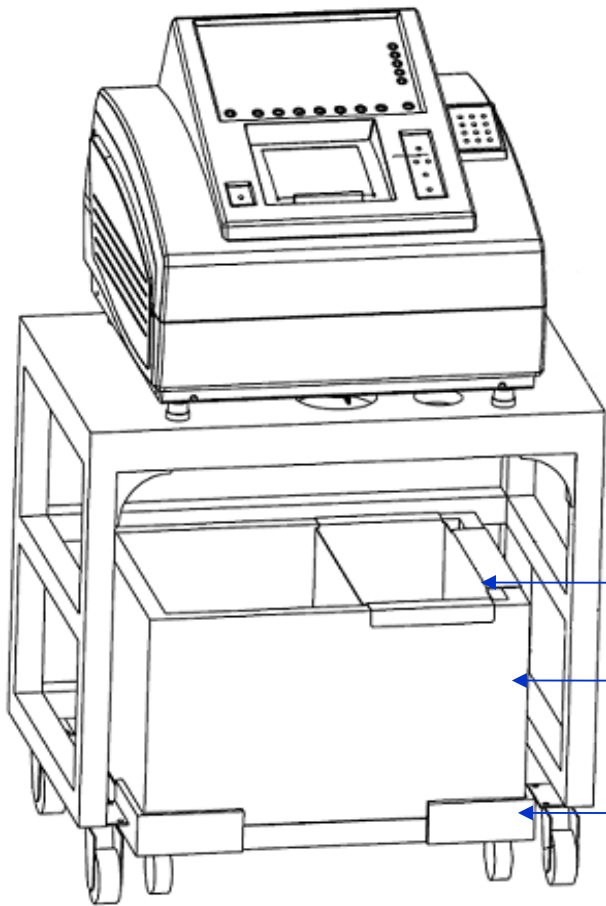

K-4-A



K-4-B



K-4-C

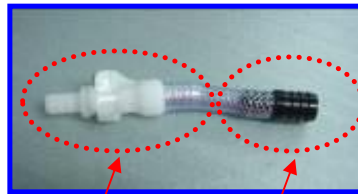

K-5

K-6



K-7



K-3

K-1

K-2

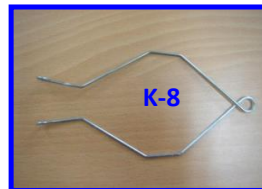

K-8



K-1



K-2

Ref. No.	Part Name	BOM Code	Remarks (for reference)	Q'ty
K-1	WATER TANK	3018A000013-A		1
K-2	WATER TANK CARRIER	3018A000014-A		1
K-3	WATER BOX STRAINER	1310A00G031-A		1
K-4-A	MOTOR(WATER PUMP)	6430TMT1000-A	ID-1000 (220V/60HZ)	1
K-4-B	MOTOR(WATER PUMP)	6430TMT1160-A	ID-1000 (110V/60HZ)	1
K-4-C	MOTOR(WATER PUMP)	6430TMT2250-A	ID-1000 (220V/50HZ)	1
K-5	COUPLING(CPC)	3018A000018-A		1
K-6	HOSE CONNECTOR	1200MPOG014-A		1
K-7	DRAIN HOSE	3018A000003-A	Length about 0.7m	1
K-8	EDGING HOSE FIXER	1310A00G033-A		1

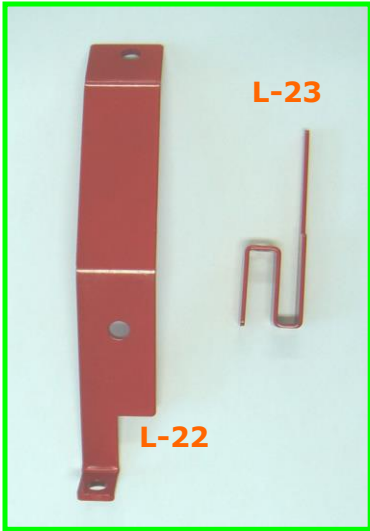

↑ There're no **Moving Fixer 1 & 2** in the tool box ass'y. These parts are in the CPE-4000 body.

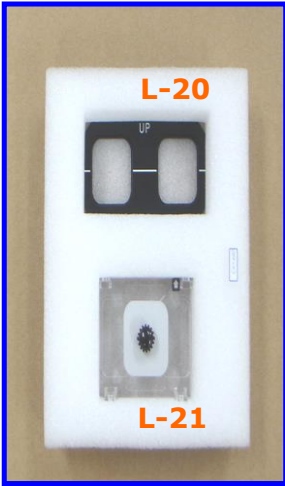
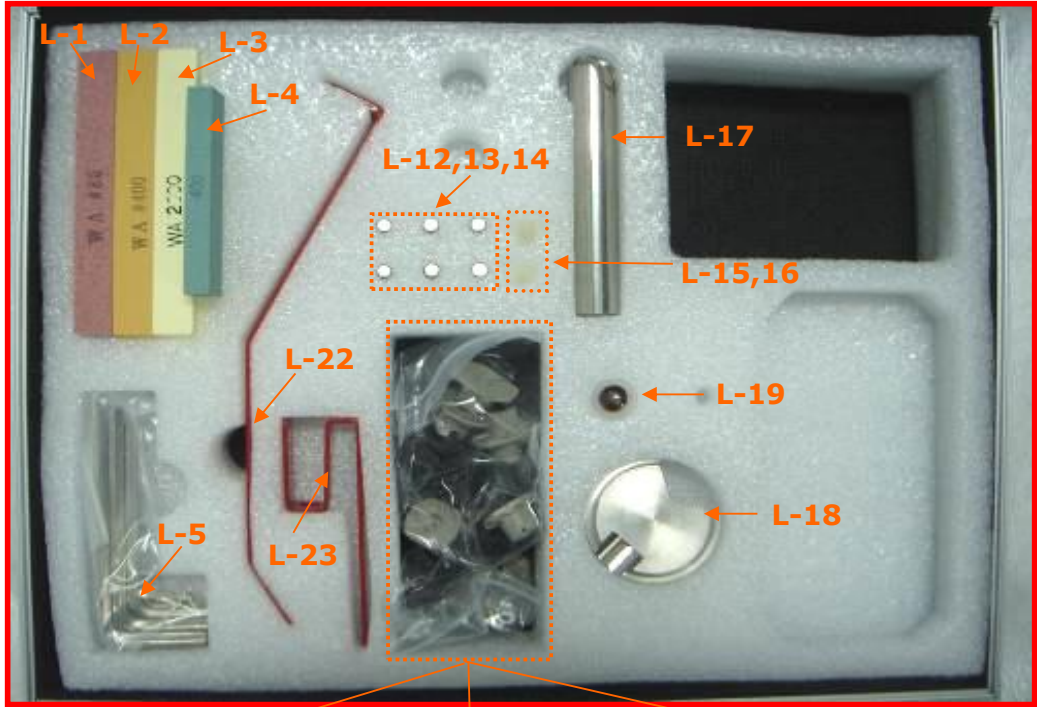

↑ **Frame Cal. Jig and Pattern Holder** are included to CFR-4000 box



Ref. No.	Part Name	BOM Code	Remarks (for reference)	Q'ty
L	TOOL BOX ASS'Y	G0MASSY800-AA		1
L-1	DRESSING STICK(WA80)	3016A000255-A	Red. For Roughing Glass Wheel	1
L-2	DRESSING STICK(WA400)	3016A000256-A	Orange. For Finishing Wheel	1
L-3	DRESSING STICK(WA2000)	3016A000257-A	Yellow. For Polishing Wheel	1
L-4	DRESSING STICK 2	3016A000245-A	GC 400K. For Polishing Wheel	1
L-5	WRENCH SET	9340A00LW15-A	7 Kinds of wrenchs (1.5m,2m,2.5m,3m,4m,5m,6m)	7
L-6	SMALL LEAP BLOCK(BLUE)	2010A000004-A	For High Curve Lens	3
L-7	SMALL LEAP BLOCK(RED)	2010A000005-A	For High Curve Lens	3
L-8	SMALL LEAP BLOCK 2(BLUE)	2010A000006-A	For Low Curve Lens	5
L-9	SMALL LEAP BLOCK 2(RED)	2010A000007-A	For Low Curve Lens	5
L-10	SMALL LEAP BLOCK 3(BLUE)	2010A000008-A	For Special Lens (water-repellent coating lens)	5
L-11	SMALL LEAP BLOCK 3(RED)	2010A000009-A	For Special Lens (water-repellent coating lens)	5
L-12	FUSE, SCHURTER	3016A000258-A	0034.3127,10A,250V	2
L-13	FUSE	3016A000259-A	50T, 250V, 0.5A, 5.2Φ, 20mm	2
L-14	FUSE	3016A000260-A	50T, 250V, 3.15A, 5.2Φ, 20mm	2
L-15	FEELER TIP SHORT	2050A00G002-A		1
L-16	FEELER TIP LONG	2050A00G003-A		1
L-17	BLOCK REMOVER	3016A000243-A		1
L-18	MAIN CALIBRATION JIG	3016A000244-A	For CPE-4000	1
L-19	LAMP, 6V, 8W	7218D005285-A	For CBK-4000	1
L-20	FRAME CALIB JIG	1200MP0H011-C	For CFR-4000 (Include to CFR-4000 box)	1
L-21	PATTERN HOLDER ASS'Y	H0MASSY028-AA	For CFR-4000 (Include to CFR-4000 box)	1
L-22	MOVING FIXER 1(P)	3016A000242-A	Include to CPE-4000 box	1
L-23	MOVING FIXER 2	3016A000246-A	Include to CPE-4000 box	1
L-24	TOOL BOX	3016A000254-A	Case	1
F-1	LEAP III PAD	3016A000287-A	1696M-24mm*18mm	1
F-2	SMALL LENS CLAMP ASS'Y	3016A000268-A		1
F-3	SMALL BLOCK ADAPTER ASS'Y	3016A000271-A		1
F-4	9 PIN CABLE FOR UPGRADE	CSEHAR001	Cable for upgrade	1
F-5	HARNESS(MAIN TO TRACER SERIAL CABLE)	GOEHAR2006-AB	FF-99S IVORY 2M	1